

# 8HP70L

8-Gang-Automatgetriebe für leichte Nutzfahrzeuge

8 speed automatic transmission for Light Commercial Vehicles

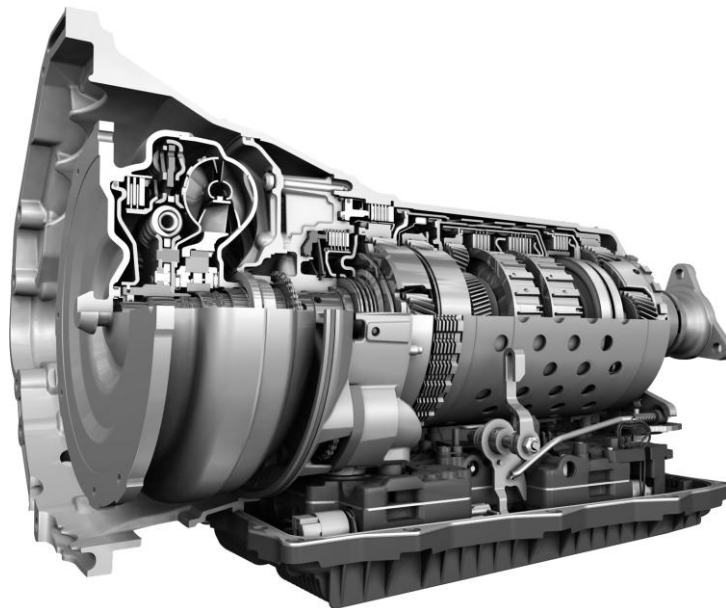

<b>Getriebetyp / Transmission type</b>		<b>8HP70L</b>
<b>Antriebsart</b> Type of drive		Standard / Standard drive
<b>Eingangsdrehmoment</b> Input torque		max. 470 Nm
<b>Drehmomentwandler</b> Torque converter		NW 250 TTD
<b>Standard-Übersetzungen / Standard ratios</b>		
Gang / Gear	1	4.714
	2	3.143
	3	2.106
	4	1.667
	5	1.285
	6	1.000
	7	0.839
	8	0.667
	R	-3.317
<b>Getriebespreizung</b> Transmissions spreading		7.05
<b>Masse ohne Anbauteile (incl. Öl)</b> Weight without ancillaries (incl. oil)		89 kg
<b>Ölmenge</b> Oil capacity		≈ 8.5 dm <sup>3</sup>
<b>Getriebeöl</b> Transmission oil		ZF LCV Arbeitszyklus/350.000 km (Ölwechsel nach 200 Tkm) ZF LCV duty cycle / 350,000 km (oil change at 200 Tkm)

# 8HP70L

## Einbaumaße / Installation dimensions

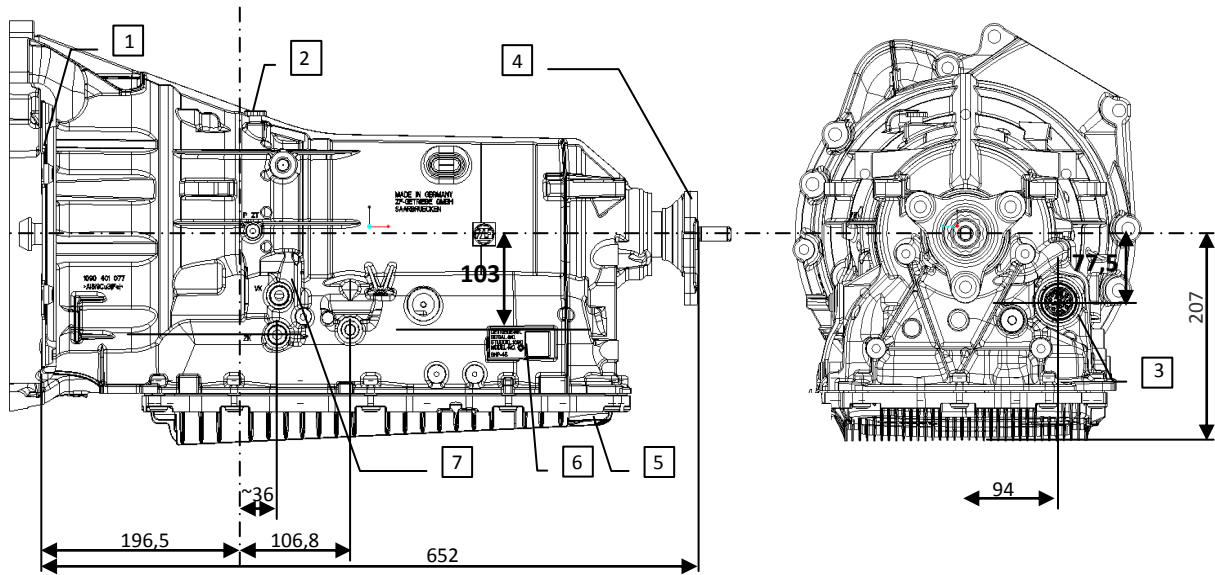

- |   |   |   |   |
|---|---|---|---|
| 1 | Wandler / Torque converter  | 5 | Ölablass / Oil drain  |
| 2 | Entlüfter / Breather  | 6 | Öleinfüllung und Ölüberlaufmessung /<br>Oil fill and oil overflow   |
| 3 | Steckeranschluss zum Fahrzeugsystem /<br>Plug connection to vehicle systems | 7 | Notentriegelung Parksperr (Shift-by-wire) oder<br>Wählhebel (manuell)<br>Emergency disengagement of parking brake<br>(Shift-by-wire) or selector lever (manually) |
| 4 | Abtrieb / Output  |   |   |

## Highlights

- Hohe Gesamtspreizung bei kleineren Gangsprüngen / High total spreading with small gear steps
- Niedere Schleppmomente / low drag torque
- Hochwirksame Torsionsschwingungsdämpfer / highly effective torsionsvibration absorber
- Mechatronik (mit integrierter TCU) / Mechatronic (with integrated TCU)
- ASIS – adaptive Schaltstrategie / ASIS – adaptive shifting strategy
- Hohe Leistung bei geringem Gewicht, Innovatives Radsatzkonzept / High power-to-weight ratio, innovative gear set concept