

6HP32

6-Gang-Automatgetriebe für Pkw
6 speed automatic transmission for cars

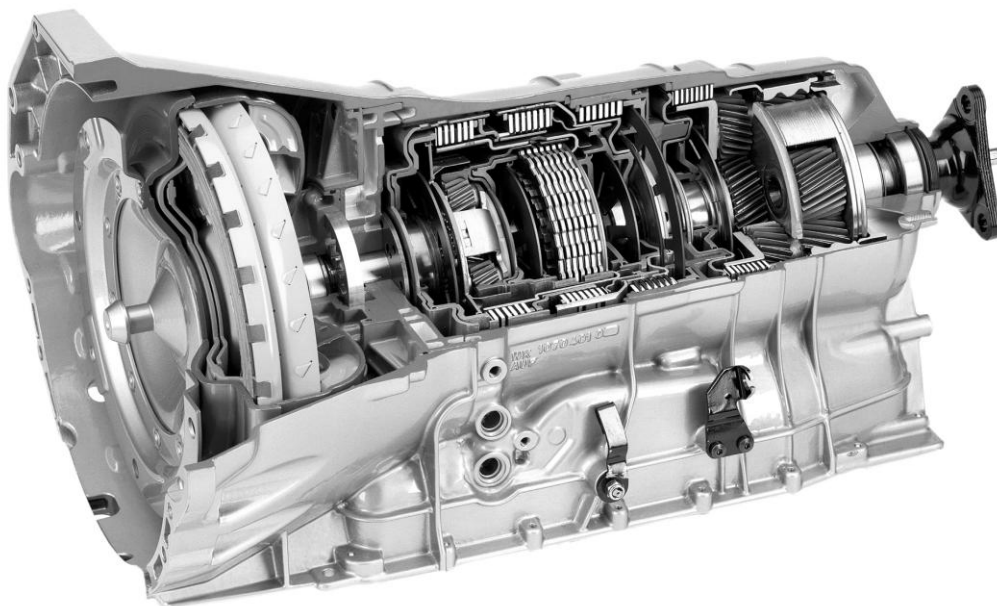

Getriebetyp / Transmission type	6HP32	
Antriebsart Type of drive	Standard / Standard drive	
Eingangsdrehmoment Input torque	max. 750 Nm	
Drehmomentwandler Torque converter	W300S- 2GWK	
Standard-Übersetzungen / Standard ratios		
Gang / Gear	1	4.17
	2	2.34
	3	1.52
	4	1.14
	5	0.87
	6	0.69
	R	3.40
Getriebespreizung Transmissions spreading	6.04	
Masse ohne Anbauteile (incl. Öl) Weight without ancillaries (incl. oil)	99 kg	
Ölmenge Oil capacity	≈ 11.2 dm ³	
Getriebeöl Transmission oil	Lebensdauerölfüllung Lifetime oil fill	

6HP32

Einbaumaße / Installation dimensions

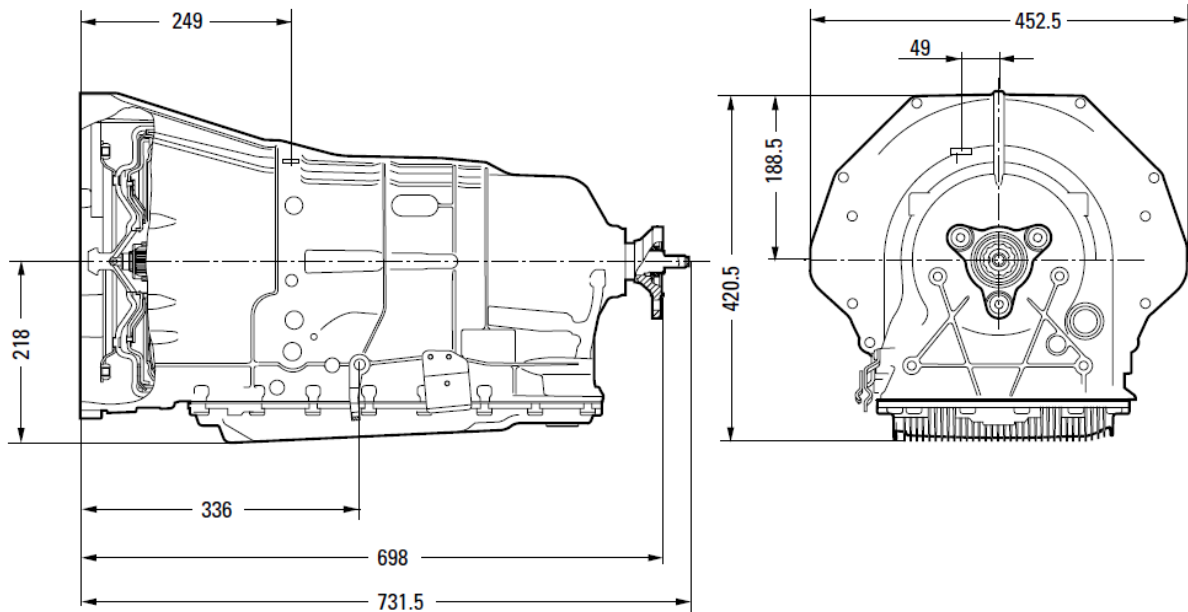

- | | | | |
|---|---|---|--|
| 1 | Wandler / Torque converter | 5 | Ölablass / Oil drain |
| 2 | Entlüfter / Breather | 6 | Öleinfüllung und Ölüberlaufmessung /
Oil fill and oil overflow |
| 3 | Steckeranschluss zum Fahrzeugsystem /
Plug connection to vehicle systems | 7 | Notentriegelung Parksperre (Shift-by-wire) oder
Wählhebel (manuell)
Emergency disengagement of parking brake
(Shift-by-wire) or selector lever (manually) |
| 4 | Abtrieb / Output | | |

Highlights

- **Standabkopplung / Neutral idle control**
- **Mechatronik (integrierte Getriebesteuerung) / Mechatronic (integrated transmission control)**
- **ASIS - adaptive Schaltstrategie / ASIS - adaptive shifting strategy**
- **Hohe Leistung bei geringem Gewicht (auf Basis des Lepelletier-Radsatzkonzeptes) /
High power-to-weight ratio (based on Lepelletier gear set concept)**