



Spare Parts Catalog

8 P 70 H SW

Material number: 1087.072.015

ZF Friedrichshafen AG

Hauptverwaltung

80038 Friedrichshafen

Deutschland

Telefon: +49 7541 77-0

Telefax: +49 7541 77-908000

www.zf.com

zuständiges Werk:

Saarbrücken



Pos.	Information	Amendment number
001	Use case -----	
002	Customer Bayerische Motoren Werke (BMW)	
003	City Muenchen	
004	DUNS 31-536-9934	
005	Vehicle / Apparatus -----	
006	Sales Name 530	
007	Manufacturer Bayerische Motoren Werke (BMW)	
008	Engineering Name F10	
009	Product Use CAR	
010	Vehicle/Hardware Type LIMOUSINE	
011	SOP	
012	Engine	
013	Sales Designation N55B30M0	
014	Manufacturer Bayerische Motoren Werke (BMW)	
015	Drivetrain type GAS	
016	Eng.Displ. 2996 cm3	
017	Cylinder 6	
018	Nom. power 225 kW	
019	RPM at nom. power 5800 1/min	
020	Nom. torque 400 Nm	
021	RPM at nom. torque 1300 1/min	
022	Classification use case -----	
023	REAR AXLE RATIO 2.93	
024	DYNAMIC TYRE RADIUS 330 mm	
029	Product description -----	
030	INSTALLATION POS TRANSMISSION LENGTHWISE	
031	DESIGN, CONSTRUCTION STAGE K40	
032	OEM BMW	
033	CODE, CUSTOMER WGW	
034	Documents -----	
035	TRANSMISSION Drawing 1087.650.003	
036	CUSTOMER RELEASE Text-document 000000353721	



Pos.	Information	Amendment number
037	Alias ID -----	
038	Bayerische Motoren Werke (BMW) 2400-7641414	

Assembly group overview

Material number: 1087.072.015

8 P 70 H SW /

Page 1 from 1



Graphics	Pos.	Material number	Name	Quantity	Amend. no.	Techn. Info.
168.28.08-1	KIT	1087.198.554	MECHATRONIC	1		

Plant

Page 1 from 1

Material number: 1087.072.015

Plant: 168.28.08-1

Material-assembly-group-no: 1087.198.554

8 P 70 H SW /

MECHATRONIC

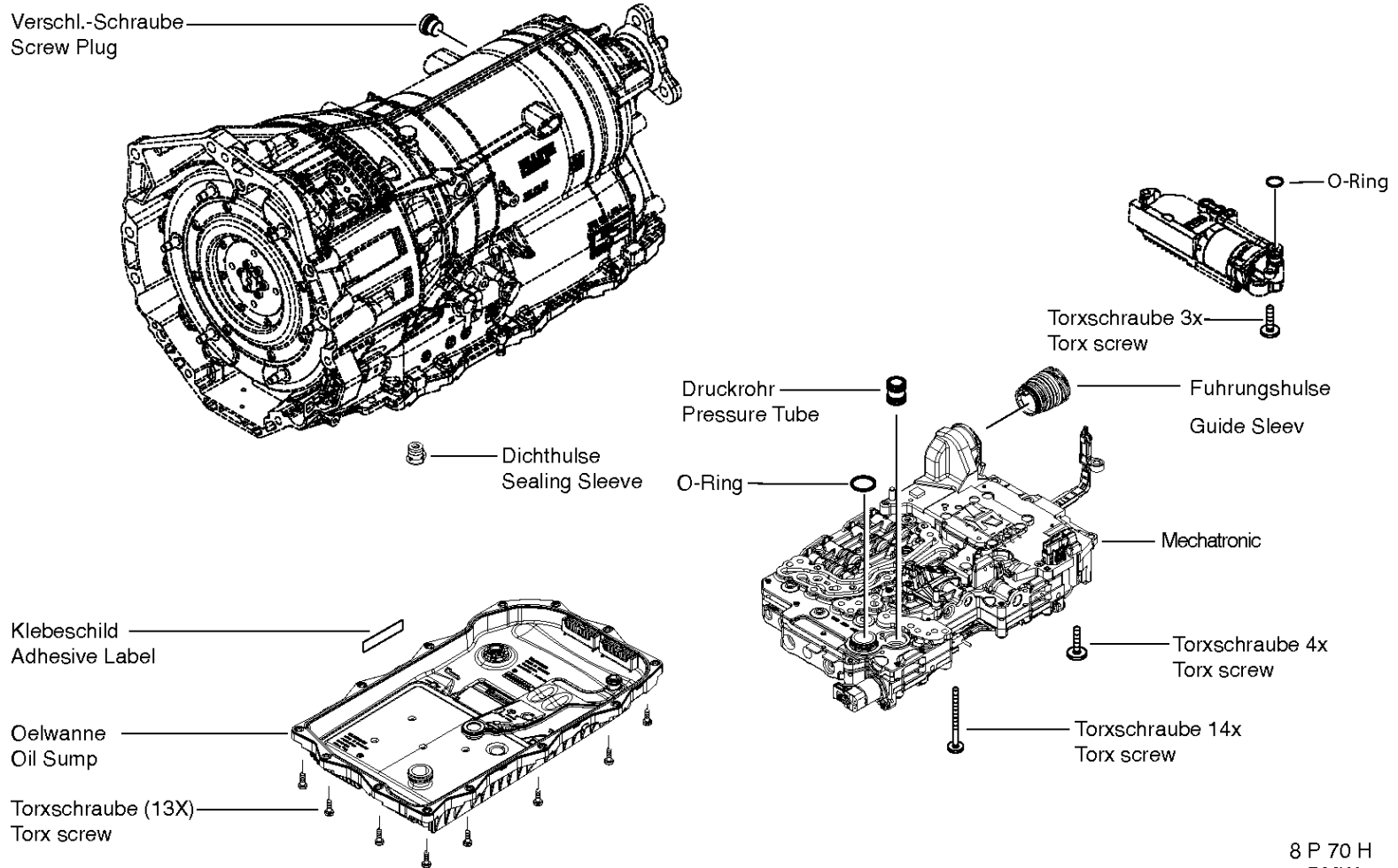

8 P 70 H
BMW

Parts list

Page 1 from 1

Material number: 1087.072.015

8 P 70 H SW /

Plant: 168.28.08-1

Material-assembly-group-no: 1087.198.554



Pos.	Material number	Customer material	Name	Quantity	ME	Amend. no.	Techn. Info.	Weight	Rep kit	Alternative material
20	0501.326.464		SEALING SLEEVE	1				0,002		
270	1087.128.554		MECHATRONIC	1			E*E26/5*MECH-S1.6* GD*HYBRID*OHNE WFS*INT.EGS*INV.PS-E	0,000		
/900	1087.150.057		VALVE HOUSING	1			E*E26/5*MECH-S1.5* GD*HYBRID*INV.PS-E	0,000		
/910	1087.151.046		VALVE PLATE	1			E*E26/5*MECH-S1.6* GD*HYBRID	0,000		
/910	6058.008.065		E-MODUL 8-GANG	1			D2-MUSTER	0,600		
/920	1087.127.842		CONTROL UNIT	1			ANBAU	0,000		
/920	1090.126.804		MODULE	1			ANBAU*INT EGS*HYBRID	0,000		
450	0736.101.348		TORX SCREW	14				0,015		
570	0736.101.375		TORX SCREW	4				0,002		
640	1087.227.004		PRESSURE TUBE	1			KPL.	0,010		
670	0501.216.364		GUIDE SLEEVE	1				0,017		
700	0637.900.038		PLUG	1				0,004		
710	0501.328.332		O-RING	1			13x2	0,002		
720	6059.311.250		SOFTWARE	1			870L4900.HEX	0,000		
722	0736.300.507		TORX SCREW	3			M6X29 M6X29	0,011		
500	1087.298.092		OIL SUMP	1			MIT BEFESTIGUNG* 8P70H*BMW*	0,000		