

6HP19

6-Gang-Automatgetriebe für Pkw
6 speed automatic transmission for cars

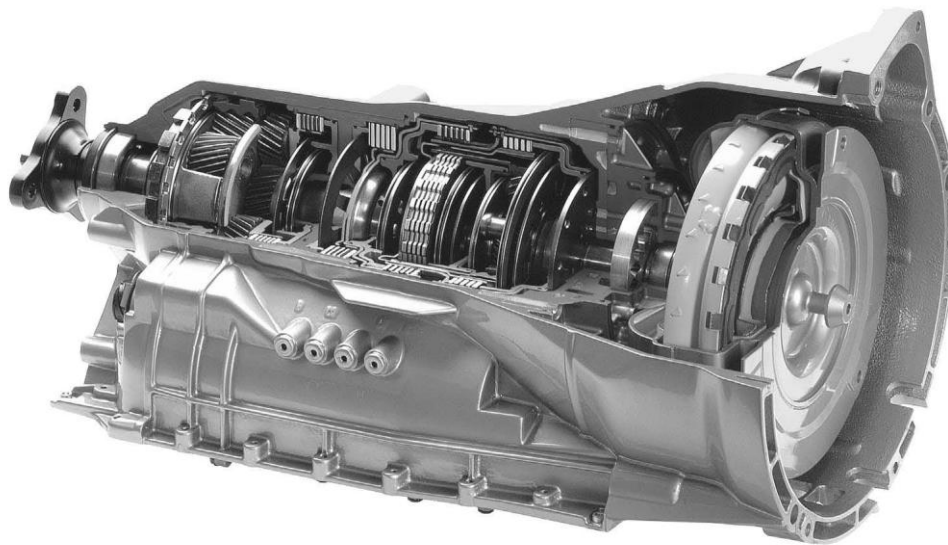

Getriebetyp / Transmission type		6HP19		
Antriebsart Type of drive		Standard / Standard drive		
Eingangsdrehmoment Input torque		max. 230 Nm	max. 320 Nm	max. 400 Nm
Drehmomentwandler Torque converter		W230SR- 2GWK	W240SR- 2GWK	W255RH- 4GWK
Standard-Übersetzungen / Standard ratios				
Gang / Gear	1	4.17		
	2	2.34		
	3	1.52		
	4	1.14		
	5	0.87		
	6	0.69		
	R	3.40		
Getriebespreizung Transmissions spreading		6.04		
Masse ohne Anbauteile (incl. Öl) Weight without ancillaries (incl. oil)		72 kg	73 kg	77 kg
Ölmenge Oil capacity		≈ 8.5 dm ³		
Getriebeöl Transmission oil		Lebensdauerölfüllung Lifetime oil fill		

6HP19

Einbaumaße / Installation dimensions

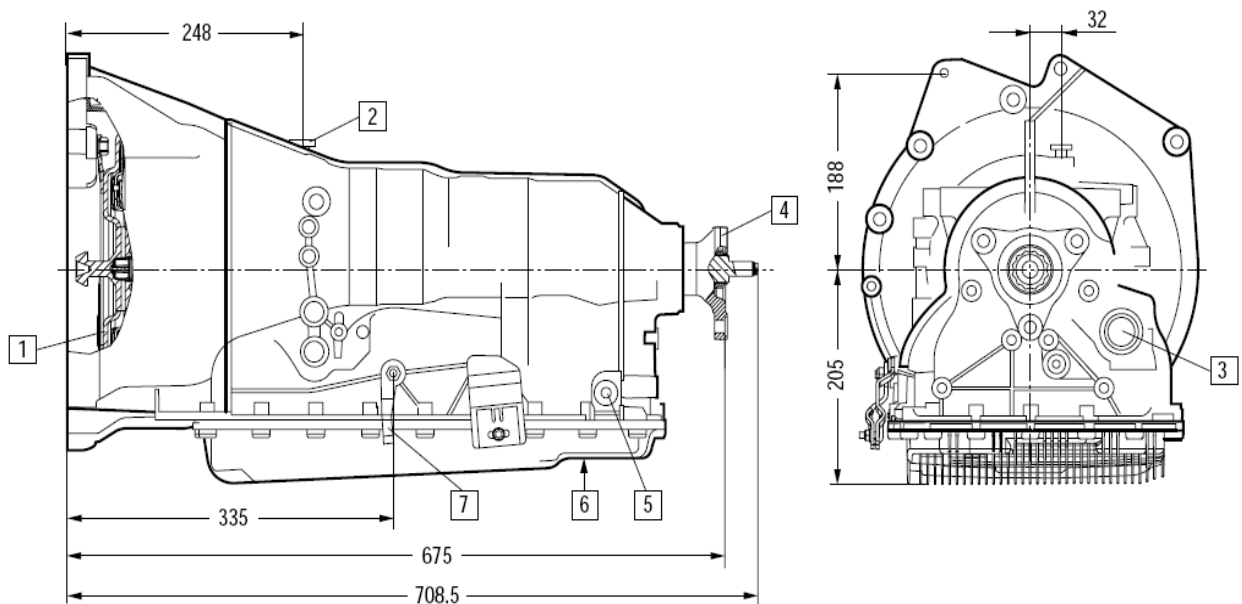

- | | | | |
|---|---|---|--|
| 1 | Wandler / Torque converter | 5 | Öleinfüllung und Ölüberlaufmessung /
Oil fill and oil overflow |
| 2 | Entlüfter / Breather | 6 | Ölablass / Oil drain |
| 3 | Steckeranschluss zum Fahrzeugsystem /
Plug connection to vehicle systems | 7 | Notentriegelung Parksperre (Shift-by-wire) oder
Wählhebel (manuell)
Emergency disengagement of parking brake
(Shift-by-wire) or selector lever (manually) |
| 4 | Abtrieb / Output | | |

Highlights

- **Standabkopplung / Neutral idle control**
- **Mechatronik (integrierte Getriebesteuerung) / Mechatronic (integrated transmission control)**
- **ASIS - adaptive Schaltstrategie / ASIS - adaptive shifting strategy**
- **Hohe Leistung bei geringem Gewicht (auf Basis des Lepelletier-Radsatzkonzeptes) / High power-to-weight ratio (based on lepelletier gear set concept)**
- **Allradfähig / AWD capable**