



Spare Parts Catalog

8 HP 45 SW

Material number: 1090.012.015

1090.010.003

ZF Friedrichshafen AG

Hauptverwaltung

80038 Friedrichshafen

Deutschland

Telefon: +49 7541 77-0

Telefax: +49 7541 77-908000

www.zf.com

zuständiges Werk:

Saarbrücken



Pos.	Information	Amendment number
001	Use case -----	
002	Customer Bayerische Motoren Werke (BMW)	
003	City Muenchen	
004	DUNS 31-536-9934	
005	Vehicle / Apparatus -----	
006	Sales Name 530	
007	Manufacturer Bayerische Motoren Werke (BMW)	
008	Engineering Name F10	
009	Product Use CAR	
010	Vehicle/Hardware Type LIMOUSINE	
011	SOP	
012	Engine	
013	Sales Designation N53B30U0	
014	Manufacturer Bayerische Motoren Werke (BMW)	
015	Drivetrain type GAS	
016	Eng.Displ. 3000 cm3	
017	Cylinder 6	
018	Nom. power 190 kW	
019	RPM at nom. power 6700 1/min	
020	Nom. torque 310 Nm	
021	RPM at nom. torque 2750 1/min	
022	Engine	
023	Sales Designation N52B25O2	
024	Manufacturer Bayerische Motoren Werke (BMW)	
025	Drivetrain type GAS	
026	Eng.Displ. 2497 cm3	
027	Cylinder 6	
028	Nom. power 150 kW	
029	RPM at nom. power 6400 1/min	
030	Nom. torque 250 Nm	
031	RPM at nom. torque 2750 1/min	
032	Classification use case -----	



Pos.	Information	Amendment number
033	CODE, CUSTOMER WF6	
037	Product description -----	
038	INSTALLATION POS TRANSMISSION LENGTHWISE	
039	DESIGN, CONSTRUCTION STAGE PVS	
041	CODE, CUSTOMER WF6	
044	Documents -----	
045	TRANSMISSION Drawing 1090.610.002	
046	8 HP 45 SW Drawing 1090.012.005	
047	Alias ID -----	
048	Bayerische Motoren Werke (BMW) 2400-7602006	

Assembly group overview

Material number: 1090.012.015

8 HP 45 SW /

Page 1 from 1



Graphics	Pos.	Material number	Name	Quantity	Amend. no.	Techn. Info.
168.28.01-1	KIT	1087.198.986	MECHATRONIC	1		
176.a1.01-1	710	1090.010.003	8 HP 45	1		

Plant

Page 1 from 1

Material number: 1090.012.015

Plant: 168.28.01-1

Material-assembly-group-no: 1087.198.986

8 HP 45 SW /

MECHATRONIC

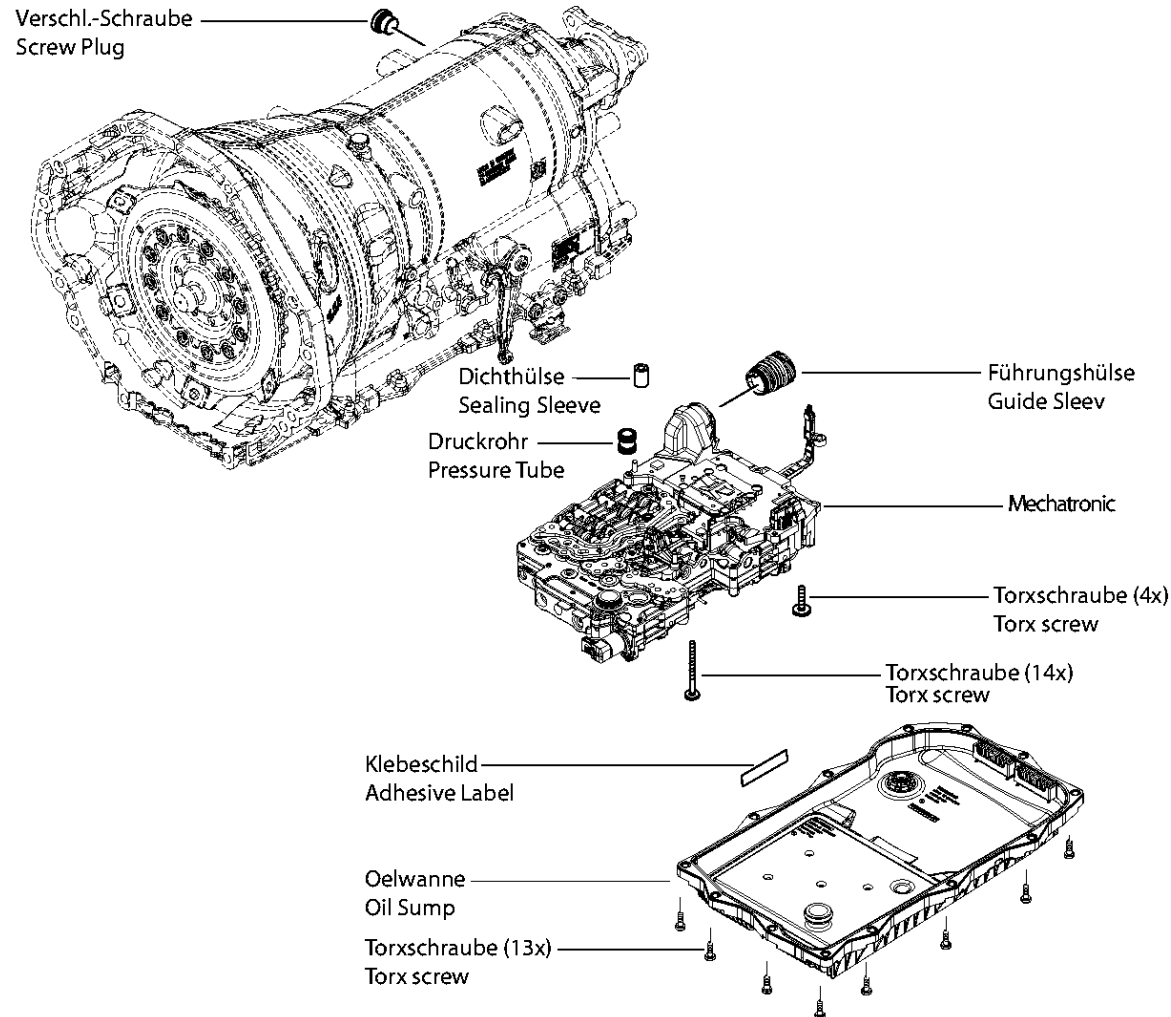

8 HP 45 / 70
BMW

Parts list

Page 1 from 1

Material number: 1090.012.015

8 HP 45 SW /

Plant: 168.28.01-1

Material-assembly-group-no: 1087.198.986



Pos.	Material number	Customer material	Name	Quantity	ME	Amend. no.	Techn. Info.	Weight	Rep kit	Alternative material
20	1087.301.006		SEALING SLEEVE	1			B IN 1087 301 012(2)	0,002		
270	1087.128.427		MECHATRONIC	1			E*INT.EGS*MECH-S1* GD	7,500		
/910	1087.151.028		VALVE PLATE	1			E*MECH-S1*GD	0,000		
/910	6058.008.065		E-MODUL 8-GANG	1		Z00006410310	D2-MUSTER	0,600		
/920	1087.126.823		MODULE	1		Z00006410310	ANBAU*C-MUSTER* INT EGS	0,000		
/920	1087.127.845		CONTROL UNIT	1			ANBAU	0,000		
450	0736.101.348		TORX SCREW	14				0,015		
570	0736.101.375		TORX SCREW	4				0,002		
640	1087.227.004		PRESSURE TUBE	1			KPL.	0,010		
670	0501.216.364		GUIDE SLEEVE	1				0,017		
700	0637.900.038		PLUG	1				0,004		
720	6059.308.014		SOFTWARE	1			845J4610.HEX	0,000		
500	1087.298.053		OIL SUMP	1			8HP45/70*45/70X+HIS* 70H*BMW*	1,350		

Plant

Page 1 from 1

Material number: 1090.012.015

Plant: 176.a1.01-1

Material-assembly-group-no: 1090.010.003

8 HP 45 SW /

8 HP 45

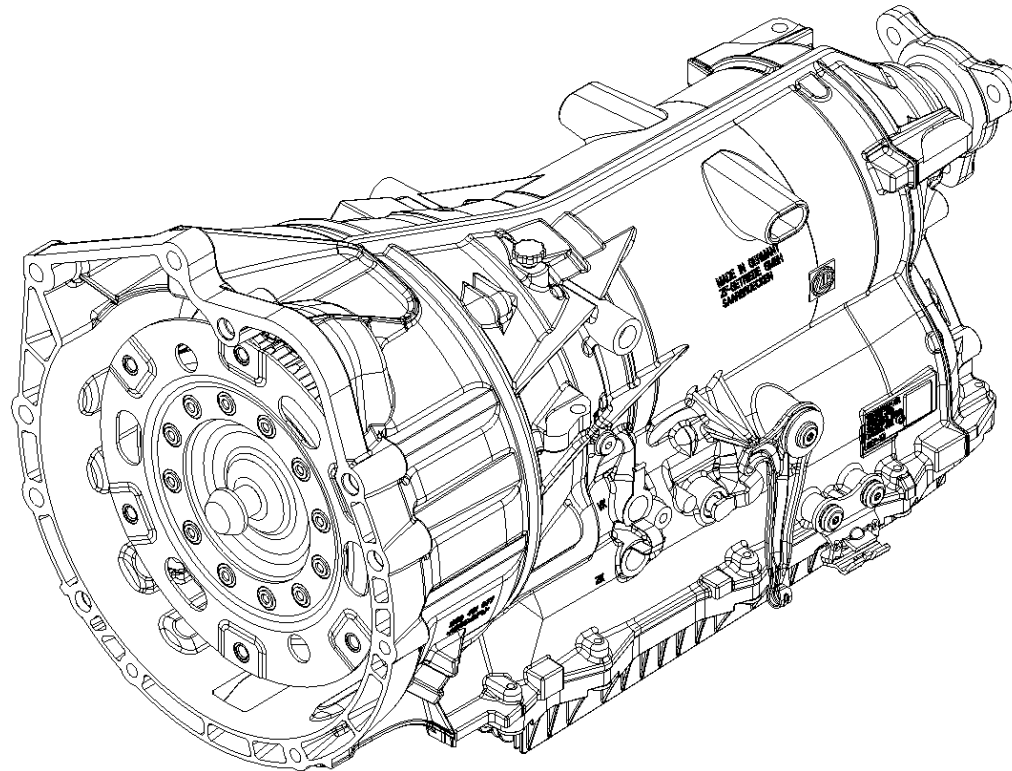

8 HP 45
BMW
N52/N55

Assembly group overview

Material number: 1090.010.003

8 HP 45 SW /



Page 1 from 2

Graphics	Pos.	Material number	Name	Quantity	Amend. no.	Techn. Info.
176.01.01-1	118	1090.101.677	GEARBOX HOUSING	1		
176.01.01-1	120	1090.101.906	GEARBOX HOUSING	1		
	170	1090.102.808	INPUT	1		
	300	1087.103.813	OIL SUMP	1		
	228	1087.106.815	GEAR SHIFT SYSTEM	1		
	198	1090.110.801	OIL SUPPLY	1		
	900	1090.110.033	OIL SUPPLY	1		
	138	1090.114.824	OUTPUT	1		
	320	1090.322.147	CONVERTER	1		
	248	1090.124.822	PARKING LOCK	1		
	920	1087.126.823	MODULE	1		
	280	1087.127.900	MECHATRONIC	1		
	920	1087.127.845	CONTROL UNIT	1		
	278	1087.128.802	MECHATRONIC	1		
	980	1090.131.823	PLANETARY DRIVE	1		
	970	1090.132.817	PLANETARY DRIVE	1		
	960	1090.140.817	PLANETARY DRIVE	1		
	900	1090.142.142	PLANETARY DRIVE	1		
	900	1090.142.809	PLANETARY DRIVE	1		
	910	1087.151.028	VALVE PLATE	1		
	920	1090.170.816	COUPLING	1		
	950	1090.171.013	COUPLING	1		
	160	1090.172.821	COUPLING	1		
	910	1090.172.825	COUPLING	1		
	910	1090.173.808	COUPLING	1		
	920	1090.173.806	COUPLING	1		
	930	1090.175.808	COUPLING	1		
	940	1090.175.011	COUPLING	1		
	84	1090.192.001	CONSERVATION	1		
114.97.11-1	62	1071.197.903	PACKING	1		
177.14.01-1	KIT	1091.298.004	OUTPUT	1		

Assembly group overview

Material number: 1090.010.003

8 HP 45 SW /

Page 2 from 2



Graphics	Pos.	Material number	Name	Quantity	Amend. no.	Techn. Info.
177.01.11-1	KIT	1091.298.003	SMALL COMPONENTS SET	1		
176.22.01-1	KIT	1090.298.031	CONVERTER	1		
168.14.11-1	KIT	1090.298.003	OUTPUT FLANGE	1		
168.06.01-1	KIT	1087.298.055	GEAR SHIFT SYSTEM	1		
168.03.01-1	KIT	1087.298.053	OIL SUMP	1		
168.22.11-1	KIT	1087.298.007	SEAL KIT	1		
168.06.11-1	KIT	1087.298.004	EMERGENCY RELEASE	1		
009.g3.01-1	KIT	1043.298.121	CLOSING COMPONENTS	1		
	910	6058.008.065	E-MODUL 8-GANG	1		

Plant

Page 1 from 1

Material number: 1090.010.003
Plant: 176.01.01-1
GEARBOX HOUSING

8 HP 45 SW /
GEARBOX HOUSING

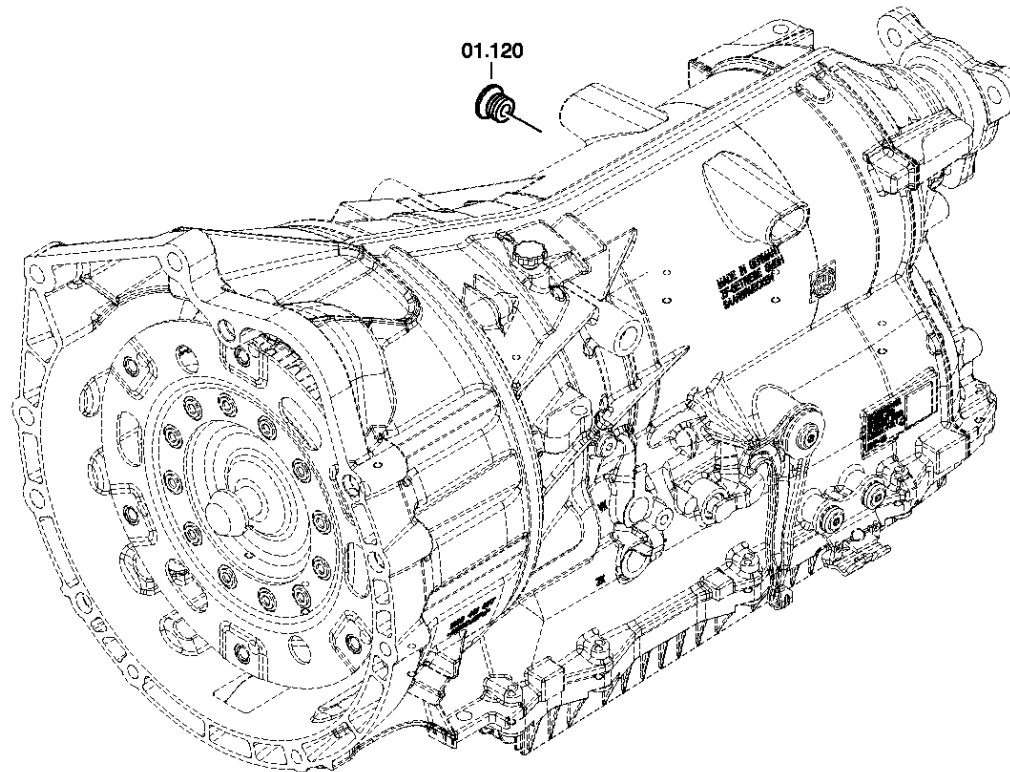

8 HP 45
BMW

Parts list

Page 1 from 1

Material number: 1090.010.003

8 HP 45 SW /

Plant: 176.01.01-1

Material-assembly-group-no: 1090.101.677



Pos.	Material number	Customer material	Name	Quantity	ME	Amend. no.	Techn. Info.	Weight	Rep kit	Alternative material
10	---		GEARBOX HOUSING	1				0,000		
20	1087.301.006		SEALING SLEEVE	1			B IN 1087 301 012(2)	0,002		
30	0631.306.127		CYLINDRICAL PIN	1			6X24	0,005		
70	0501.314.851		BREATHER TUBE	1				0,006		
80	0501.314.809		BREATHER COVER	1				0,001		
100	0501.321.921		SCREW PLUG	1			M10X1	0,008		
120	0501.321.922		SCREW PLUG	1				0,032		
140	0501.326.152		PLUG	1				0,003		
840	0666.692.055		CODE LABEL	1				0,001		

Parts list

Page 1 from 1

Material number: 1090.010.003

8 HP 45 SW /

Material-assembly-group-no: 1090.102.808



Pos.	Material number	Customer material	Name	Quantity	ME	Amend. no.	Techn. Info.	Weight	Rep kit	Alternative material
50	0735.368.294		AXIAL NEEDLE BEARING	1			50,8X67,5X4 FA.INA	0,040		
70	1090.231.071		RING GEAR	1			RS1	1,517		
80	0501.327.285		ANGLE DISC	1				0,027		
170	0734.313.897		ROUND SEALING RING	1			23,52X1,78	0,003		

Parts list

Page 1 from 1

Material number: 1090.010.003

8 HP 45 SW /

Material-assembly-group-no: 1087.103.813



Pos.	Material number	Customer material	Name	Quantity	ME	Amend. no.	Techn. Info.	Weight	Rep kit	Alternative material
10	0501.218.048		OIL SUMP	1				1,260		
/10	0501.324.810		GASKET	1				0,052		
/20	0501.323.928		O-RING	1				0,002		
/30	0501.325.941		SCREW PLUG	1				0,008		
20	0501.326.933		ADHESIVE LABEL	1				0,001		
30	0736.101.486		TORX SCREW	13				0,012		

Parts list

Page 1 from 1

Material number: 1090.010.003

8 HP 45 SW /

Material-assembly-group-no: 1087.106.815



Pos.	Material number	Customer material	Name	Quantity	ME	Amend. no.	Techn. Info.	Weight	Rep kit	Alternative material
10	0734.319.801		SHAFT SEAL	1			10X18X5	0,002		
30	1087.206.019		SELECTOR SHAFT	1				0,060		
50	1087.206.028		PARKING LOCK DISC	1				0,107		
60	0501.324.683		CLAMPING SLEEVE	1				0,003		
90	1087.306.055		LEG SPRING	1				0,021		
130	1087.206.030		ANGLE BRACKET	1				0,101		
/110	1087.306.047		ANGLE BRACKET	1				0,063		
/120	1087.306.043		ANGLE BRACKET	1				0,021		
/130	---		HEXAGON BOLT	1			M6X18	0,000		
---	1087.306.044		HEXAGON BOLT	1				0,008		
/140	0501.326.132		RUBBER SOCKET	2				0,001		
/150	1068.306.074		BUSH	2			NOTENTRIEGELUNG* BMW	0,004		
170	0736.300.109		CAP SCREW	2			M6X15,8 M6X15,8	0,011		
180	1087.206.024		RELEASE LEVER	1				0,087		
210	1087.206.026		SCREW	1				0,016		

Parts list

Page 1 from 1

Material number: 1090.010.003

8 HP 45 SW /

Material-assembly-group-no: 1090.110.801



Pos.	Material number	Customer material	Name	Quantity	ME	Amend. no.	Techn. Info.	Weight	Rep kit	Alternative material
10	1090.210.110		INTERMPLATE	1				0,000		
20	0735.298.399		NEEDLE SLEEVE	1			W-KAEFIG 33,0X39, 0x21,0	0,029		
30	0730.514.096		SNAP RING	1				0,004		
40	0501.218.885		PUMP	1				0,000		
60	0501.329.171		CHAIN	1				0,068		
80	1087.210.266		SPROCKET WHEEL	1			KPL. VERB.TOLERANZ	0,000		
/110	---		SPROCKET WHEEL	1			WTB	0,000		
/120	0501.326.875		UNDULATSPRING	1				0,700		
/130	0501.323.708		PISTON RING	1				0,007		
/140	0501.326.909		ANGLE DISC	1				0,010		
100	1090.210.128		CENTERING PLATE	1			KPL.	0,000		
110	0736.010.388		TORX SCREW	6			M6X24	0,003		
200	0734.313.893		ROUND SEALING RING	1			271X3	0,008		
210	---		SHIM	1			S= 3,40 - 4,80(ABSTUFUNG: 0,20MM)	0,000		
---	0501.325.565		SHIM	1			T=4,8	0,067		
---	0501.325.564		SHIM	1			T=4,6	0,064		
---	0501.325.563		SHIM	1			T=4,4	0,061		
---	0501.325.562		SHIM	1			T=4,2	0,059		
---	0501.325.561		SHIM	1			T=4,0	0,056		
---	0501.325.560		SHIM	1			T=3,8	0,053		
---	0501.325.559		SHIM	1			T=3,6	0,050		
---	0501.324.915		SHIM	1			T=3,4 IN 0501 324 907(2)	0,028		
230	0736.300.068		TORX SCREW	13			M8X70	0,013		

Parts list

Page 1 from 1

Material number: 1090.010.003

8 HP 45 SW /

Material-assembly-group-no: 1090.114.824



Pos.	Material number	Customer material	Name	Quantity	ME	Amend. no.	Techn. Info.	Weight	Rep kit	Alternative material
10	0501.326.060		NEEDLE SLEEVE	1				0,104		
20	1087.314.026		SNAP RING	1				0,007		
30	0501.326.212		SEALING SLEEVE	1		Z00004276310		0,033		
34	1087.342.136		SNAP RING	1				0,007		
50	0735.300.104		BALL BEARING	1			35,0X72,0X17,0	0,290		
70	1087.314.023		SNAP RING	1				0,022		
90	0734.319.633		SHAFT SEAL	1				0,027		
100	0730.112.642		SHIM	1		Z00004276310	A=1,00	0,005		
120	1071.314.006		OUTPUT FLANGE	1		Z00004276310	Z=43	0,676		
140	0501.327.252		SEALING RING	1			28X35,5X5,2	0,007		
160	0501.324.215		COLLAR NUT	1		Z00004276310	M27X1,5	0,053		

Parts list

Page 1 from 1

Material number: 1090.010.003

8 HP 45 SW /

Material-assembly-group-no: 1090.322.147



Pos.	Material number	Customer material	Name	Quantity	ME	Amend. no.	Techn. Info.	Weight	Rep kit	Alternative material
	1090.322.147		CONVERTER	1			163*D139	14		

Parts list

Page 1 from 1

Material number: 1090.010.003

8 HP 45 SW /

Material-assembly-group-no: 1090.124.822



Pos.	Material number	Customer material	Name	Quantity	ME	Amend. no.	Techn. Info.	Weight	Rep kit	Alternative material
10	1087.324.022		PIN	1				0,055		
20	0501.321.922		SCREW PLUG	1				0,032		
40	1087.324.074		PAWL	1				0,243		
60	1087.324.099		LEG SPRING	1				0,008		
80	1090.224.059		CONNECTING BAR	1				0,093		
110	1087.324.139		GUIDING PLATE	1				0,083		
120	1087.324.045		HEXALOBULAR DRIVING SCREW	3			M6X20*PRECOTE 85-3	0,007		

Parts list

Page 1 from 1

Material number: 1090.010.003

8 HP 45 SW /

Material-assembly-group-no: 1087.126.823



Pos.	Material number	Customer material	Name	Quantity	ME	Amend. no.	Techn. Info.	Weight	Rep kit	Alternative material
30	0736.101.354		TORX SCREW	5			M5X60 IN 0736 101 351(1)	0,010		
110	1087.227.029		WIRING HARNESS	1			8HP E-SCHALT PZYL	0,038		
/100	6029.201.996		PLUG	1			8POL BU MLK KOSTAL 8HP	0,000		
/200	6029.207.902		PLUG	1			2POL ST MPQ 2.8 0,5/0,5	0,027		
/201	0659.120.090		LINE	480				0,000		
/202	0659.120.086		LINE	480				0,000		
/9201	0501.324.947		BOTTOM	1			KABELKANAL	0,000		
/9202	0501.324.946		COVER	1			KABELKANAL	0,000		

Parts list

Page 1 from 1

Material number: 1090.010.003

8 HP 45 SW /

Material-assembly-group-no: 1087.127.900



Pos.	Material number	Customer material	Name	Quantity	ME	Amend. no.	Techn. Info.	Weight	Rep kit	Alternative material
690	1068.227.022		VALVE	4				0,008		
710	1068.227.061		VALVE	1			KPL. IN 1060 227 018(2)	0,001		
730	1087.327.041		PISTON	1			SDB V	0,001		
740	0732.300.017		COMPRSPRING	1				0,002		
760	0501.216.254		SCREEN FILTER	1				0,001		
770	1068.327.098		BALL	6				0,149		
780	0501.311.653		SCREEN	1				0,002		
790	1068.327.143		SPHERICAL PIECE	1				0,001		
800	1068.227.039		PISTON	7				0,010		
820	1087.227.012		SUCTION CONNECTOR	1			KPL. *8HP* OELVERSORGUNG	0,017		
830	0501.227.048		INTERMEDIATE SHEET	1			E*E26/1/6*MECH-S1	0,271		
/10	1087.327.175		INTERMEDIATE SHEET	1			E*E26/1/6*MECH-S1	0,269		
/20	0501.324.233		GASKET	1			SIEBDRUCK	0,000		
840	0736.101.352		TORX SCREW	20				0,008		
850	1068.327.144		CAP	1				0,005		

Parts list

Page 1 from 1

Material number: 1090.010.003

8 HP 45 SW /

Material-assembly-group-no: 1087.128.802



Pos.	Material number	Customer material	Name	Quantity	ME	Amend. no.	Techn. Info.	Weight	Rep kit	Alternative material
450	0736.101.348		TORX SCREW	14				0,015		
570	0736.101.375		TORX SCREW	3				0,002		
580	0736.101.375		TORX SCREW	1				0,002		
640	1087.227.004		PRESSURE TUBE	1			KPL.	0,010		
670	0501.216.364		GUIDE SLEEVE	1				0,017		

Parts list

Page 1 from 1

Material number: 1090.010.003

8 HP 45 SW /

Material-assembly-group-no: 1090.131.823



Pos.	Material number	Customer material	Name	Quantity	ME	Amend. no.	Techn. Info.	Weight	Rep kit	Alternative material
10	1090.231.136		PLANETARY DRIVE	1			KPL.RS1/3PL.*OPT.V2	0,000		
20	1090.331.075		SNAP RING	1			RS I	0,038		

Parts list

Page 1 from 1

Material number: 1090.010.003

8 HP 45 SW /

Material-assembly-group-no: 1090.132.817



Pos.	Material number	Customer material	Name	Quantity	ME	Amend. no.	Techn. Info.	Weight	Rep kit	Alternative material
10	1090.232.108		PLANETARY DRIVE	1			3PL	1,227		
20	1090.332.012		OIL TRAY	1			RS II 3PL	0,008		
30	1090.232.054		INPUT SHAFT	1			KPL.	2,295		
/110	1090.332.057		INPUT SHAFT	1				2,298		
/120	1087.332.037		SEALING SLEEVE	1			3L WANDLER	0,019		
/130	0501.327.169		PLUG	1			VERLÄNGERT	2,510		
/140	0501.327.169		PLUG	1			VERLÄNGERT	2,510		
50	1090.332.027		SNAP RING	1				0,008		
60	0501.324.727		ANGLE DISC	1				0,018		
80	0501.327.948		PISTON RING	5			31,4X2	0,001		
90	0501.327.948		PISTON RING	2			31,4X2	0,001		
120	1090.332.073		SUN GEAR	1			RS1*2	0,559		

Parts list

Page 1 from 1

Material number: 1090.010.003

8 HP 45 SW /

Material-assembly-group-no: 1090.140.817



Pos.	Material number	Customer material	Name	Quantity	ME	Amend. no.	Techn. Info.	Weight	Rep kit	Alternative material
10	0735.368.300		AXIAL NEEDLE BEARING	1			46,3X63,0X4,0	0,030		
30	1090.375.018		SNAP RING	1			2X2 GRAD KONISCH	0,026		
50	1090.340.022		RING GEAR	1				0,156		
70	1090.375.018		SNAP RING	1			2X2 GRAD KONISCH	0,026		
100	1090.240.058		PLANETARY DRIVE	1				0,582		
120	0501.327.470		AXIAL NEEDLE BEARING	1			50,8X67,5X4,0	0,029		
140	1090.340.027		SNAP RING	1				0,044		
160	1090.240.057		SUN GEAR	1			KPL. RS3	0,000		
170	0735.300.299		AXIAL NEEDLE BEARING	1			46,8X85,0X3,8 FA.INA	0,045		

Parts list

Page 1 from 1

Material number: 1090.010.003

8 HP 45 SW /

Material-assembly-group-no: 1090.142.142



Pos.	Material number	Customer material	Name	Quantity	ME	Amend. no.	Techn. Info.	Weight	Rep kit	Alternative material
10	1090.242.201		OUTPUT SHAFT	1				3,193		
20	0501.324.816		PLUG	1				0,001		
26	1087.342.073		SEALING CAP	1				0,001		
30	0735.368.310		AXIAL NEEDLE BEARING	1			27,5x44,5x5,0	0,026		
80	0501.326.442		PIN	4			RS4	0,113		
90	0735.321.677		NEEDLE CAGE	4			23,0X31,0X25,8	0,044		
100	1090.342.191		PLANET GEAR	4			RS4	0,220		
110	0730.300.989		THRUST WASHER	8				0,007		
160	1090.342.048		SNAP RING	1				0,018		
180	0501.327.840		CYLINDER	1				0,236		
200	1090.342.062		RING GEAR	1			RS4 Z60	0,668		
220	1090.342.080		POT	1			RS1	0,701		
240	1090.342.072		SNAP RING	1				0,029		
270	0734.307.424		PISTON RING	2				0,001		

Parts list

Page 1 from 1

Material number: 1090.010.003

8 HP 45 SW /

Material-assembly-group-no: 1087.151.028



Pos.	Material number	Customer material	Name	Quantity	ME	Amend. no.	Techn. Info.	Weight	Rep kit	Alternative material
10	1087.327.174		VALVE PLATE	1				2,020		
30	1087.327.043		PISTON	1			WD-V	0,008		
40	0732.041.921		COMPRSPRING	1				0,002		
60	1068.327.160		PLUG	1			ENTHALT.IN 1068 327 158(2)	0,004		
70	1068.327.021		SPRING CLAMP	1				0,005		
140	1085.327.010		PISTON	1			POSITIONS-VENTIL	0,003		
150	1085.327.009		PISTON	1			POSITIONS-VENTIL	0,010		
160	0732.300.050		COMPRSPRING	1				0,002		
170	1043.323.105		SUPPORT PLATE	1				0,002		
190	1087.327.238		PISTON	1		Z00012266810		0,006		
200	0732.300.159		COMPRSPRING	1		Z00012266810		0,002		
220	1043.323.105		SUPPORT PLATE	1				0,002		
240	1087.327.134		PISTON	1				0,006		
250	0732.041.856		COMPRSPRING	1				0,002		
270	1043.323.105		SUPPORT PLATE	1				0,002		
280	1087.327.130		PISTON	1				0,007		
310	0732.042.853		COMPRSPRING	1			HYDR. SCHALTGERAET	0,003		
320	1043.323.105		SUPPORT PLATE	1				0,002		
330	1087.327.130		PISTON	1				0,007		
350	0732.042.853		COMPRSPRING	1			HYDR. SCHALTGERAET	0,003		
360	1043.323.105		SUPPORT PLATE	1				0,002		

Parts list

Page 1 from 1

Material number: 1090.010.003

8 HP 45 SW /

Material-assembly-group-no: 1090.170.816



Pos.	Material number	Customer material	Name	Quantity	ME	Amend. no.	Techn. Info.	Weight	Rep kit	Alternative material
10	1090.370.006		PISTON	1			A	0,133		
30	0501.323.593		LIP SEALING RING	1			116,8X126,8X3,9X2,5	0,006		
50	0501.323.592		LIP SEALING RING	1				0,454		
70	0501.324.786		CUP SPRING	1				0,065		
80	1087.370.014		SPLIT RING	1			A	0,016		
90	0501.327.470		AXIAL NEEDLE BEARING	1			50,8X67,5X4,0	0,029		
100	0501.323.623		ANGLE DISC	1				0,012		
110	---		SUN GEAR SHAFT	1			*8HP45	0,000		
120	0501.324.792		UNDULATSPRING	1				0,032		
130	1090.370.002		OCLUTCH DISC	4			A	0,072		
140	0501.324.710		FRICTION PLATE	4				0,031		
150	1090.370.003		END DISC	1				0,121		
160	---		SNAP RING	1			WTB 1090 370 019 -A= 2,2 - 3,2 (ABSTUFUNG: 0,20MM)	0,000		
---	1090.370.027		SNAP RING	1			S=3,2	0,041		
---	1090.370.026		SNAP RING	1			S=3,0	0,039		
---	1090.370.025		SNAP RING	1			S=2,8	0,036		
---	1090.370.024		SNAP RING	1			S=2,6	0,034		
---	1090.370.023		SNAP RING	1			S=2,4	0,031		
---	1090.370.022		SNAP RING	1			S=2,2	0,028		
220	0501.327.470		AXIAL NEEDLE BEARING	1			50,8X67,5X4,0	0,029		

Parts list

Page 1 from 1

Material number: 1090.010.003

8 HP 45 SW /

Material-assembly-group-no: 1090.171.013



Pos.	Material number	Customer material	Name	Quantity	ME	Amend. no.	Techn. Info.	Weight	Rep kit	Alternative material
10	1090.271.010		CYLINDER	1				0,396		
30	0501.324.794		UNDULATSPRING	1				0,026		
40	1090.375.019		ICLUTCH DISC	5			A=2,1	0,089		
50	0501.325.962		FRICTION PLATE	5				0,078		
60	---		ICLUTCH DISC	1			S=3,00-4,50 (ABSTUFUNG:0,3MM)	0,000		
---	1090.375.015		ICLUTCH DISC	1			A=4.5 1090 375 007(1)	0,192		
---	1090.375.014		ICLUTCH DISC	1			A=4.2 1090 375 007(1)	0,179		
---	1090.375.013		ICLUTCH DISC	1			A=3.9 1090 375 007(1)	0,166		
---	1090.375.012		ICLUTCH DISC	1			A=3.6 1090 375 007(1)	0,153		
---	1090.375.011		ICLUTCH DISC	1			A=3.3 1090 375 007(1)	0,141		
---	1090.375.010		ICLUTCH DISC	1			A=3.0 1090 375 007(1)	0,128		
70	0501.326.355		CUP SPRING	1				0,053		
80	0734.313.895		ROUND SEALING RING	1			38,5X2,65	0,001		
90	0734.300.255		ROUND SEALING RING	1			41X1,5	0,001		
100	0501.325.337		PISTON	1				0,459		
110	1090.371.011		SUPPORT SHIM	1				0,098		
120	0501.324.413		LIP SEALING RING	1			81,8X91,8X3,9X2,5	0,004		
140	1087.371.015		WIRE RING	1				0,008		

Parts list

Page 1 from 1

Material number: 1090.010.003

8 HP 45 SW /

Material-assembly-group-no: 1090.172.821



Pos.	Material number	Customer material	Name	Quantity	ME	Amend. no.	Techn. Info.	Weight	Rep kit	Alternative material
10	0501.324.796		UNDULATSPRING	1				0,048		
20	1090.372.016		OCLUTCH DISC	4			B/T=1.8 IN 1090 372 015(1)	0,102		
30	0501.329.161		FRICITION PLATE	4				0,045		
40	---		OCLUTCH DISC	1		Z00007685010	S= 4,60- 5,80(ABSTUFUNG:0,20MM)	0,000		
---	1090.372.066		OCLUTCH DISC	1			A=5,8	0,334		
---	1090.372.065		OCLUTCH DISC	1			A=5,6	0,322		
---	1090.372.054		OCLUTCH DISC	1			A=5.4 A=5.4	0,311		
---	1090.372.064		OCLUTCH DISC	1			A=5,2	0,299		
---	1090.372.063		OCLUTCH DISC	1			A=5,0	0,288		
---	1090.372.056		OCLUTCH DISC	1			A=4.8 A=4.8	0,276		
---	1090.372.062		OCLUTCH DISC	1			A=4,6	0,265		
100	1090.372.034		PISTON	1				0,301		
110	0501.323.594		LIP SEALING RING	1				0,008		
120	0501.325.521		PROFILE SEALING RING	1				0,008		
130	0501.324.725		CYLINDER	1				0,178		
140	0734.313.914		ROUND SEALING RING	1			177X2,65	0,004		

Parts list

Page 1 from 1

Material number: 1090.010.003

8 HP 45 SW /

Material-assembly-group-no: 1090.173.808



Pos.	Material number	Customer material	Name	Quantity	ME	Amend. no.	Techn. Info.	Weight	Rep kit	Alternative material
30	1090.273.003		PISTON	1			KPL.	0,520		
/10	1090.373.018		PISTON	1				0,415		
/20	1090.373.010		OIL BAFFLE PLATE	1			D	0,110		
50	0734.313.033		ROUND SEALING RING	1			ENTHALT.IN 0734 313 005(1)	0,001		
70	0501.324.788		CUP SPRING	1				0,060		
80	1090.373.006		OIL DAM	1			D	0,127		
100	0734.313.027		ROUND SEALING RING	1			ENTHALT.IN 0734 313 005(1)	0,002		
120	0501.324.795		UNDULATSPRING	1				0,024		
140	1090.373.004		OCLUTCH DISC	4			D	0,089		
160	0501.325.445		FRICITION PLATE	4				0,039		
170	1090.373.005		OCLUTCH DISC	1			D ENDLAMELLE GENOPPT	0,128		
180	---		SNAP RING	1			S= 1,60- 3,00(ABSTUFUNG:0,20MM)	0,000		
---	0730.514.136		SNAP RING	1			A=3,00	0,046		
---	0730.514.135		SNAP RING	1			A=2,80	0,043		
---	0730.514.134		SNAP RING	1			A=2,60	0,040		
---	0730.514.133		SNAP RING	1			A=2,40	0,037		
---	0730.514.132		SNAP RING	1			A=2,20	0,034		
---	0730.514.131		SNAP RING	1			A=2,00	0,031		
---	0730.514.130		SNAP RING	1			A=1,80	0,028		
---	0730.514.129		SNAP RING	1			A=1,60	0,025		
250	1090.373.020		POT	1				0,719		

Parts list

Page 1 from 1

Material number: 1090.010.003

8 HP 45 SW /

Material-assembly-group-no: 1090.175.808



Pos.	Material number	Customer material	Name	Quantity	ME	Amend. no.	Techn. Info.	Weight	Rep kit	Alternative material
10	1090.375.030		HUB	1				0,251		
20	0734.313.896		ROUND SEALING RING	2			31,5X2 IN 0734 313 005(0)	0,001		
50	---		CYLINDER	1				0,000		
60	0501.324.794		UNDULATSPRING	1				0,026		
80	1090.375.019		ICLUTCH DISC	5			A=2,1	0,089		
100	0501.325.962		FRICTION PLATE	5				0,078		
110	---		ICLUTCH DISC	1			S=3,00-4,50 (ABSTUFUNG:0,3MM)	0,000		
---	1090.375.015		ICLUTCH DISC	1			A=4.5 1090 375 007(1)	0,192		
---	1090.375.014		ICLUTCH DISC	1			A=4.2 1090 375 007(1)	0,179		
---	1090.375.013		ICLUTCH DISC	1			A=3.9 1090 375 007(1)	0,166		
---	1090.375.012		ICLUTCH DISC	1			A=3.6 1090 375 007(1)	0,153		
---	1090.375.011		ICLUTCH DISC	1			A=3.3 1090 375 007(1)	0,141		
---	1090.375.010		ICLUTCH DISC	1			A=3.0 1090 375 007(1)	0,128		
120	0501.324.787		CUP SPRING	1				0,054		
130	0734.313.905		ROUND SEALING RING	2			34,8X2,65	0,001		
160	0501.325.338		PISTON	1				0,378		
180	1090.375.027		SUPPORT SHIM	1				0,080		
200	0501.323.595		LIP SEALING RING	1			77,1X87,1X3,9X2,5	0,010		
220	1090.375.017		SNAP RING	1			STUETZSCHEIBE	0,008		
300	1090.242.194		SUN GEAR SHAFT	1			RS4	1,357		
330	0735.368.310		AXIAL NEEDLE BEARING	1		Z00013962610	27,5x44,5x5,0	0,026		
350	0735.368.316		AXIAL NEEDLE BEARING	1		Z00013962610	31,4X48,4X5,0	0,028		

Parts list

Page 1 from 1

Material number: 1090.010.003

8 HP 45 SW /

Material-assembly-group-no: 1090.192.001



Pos.	Material number	Customer material	Name	Quantity	ME	Amend. no.	Techn. Info.	Weight	Rep kit	Alternative material
	1090.192.001		CONSERVATION	1			KA 0/KI 1*ZFN916* PRUEFST. *8,61DM3 GE/WT	0,000		

Plant

Page 1 from 1

Material number: 1090.010.003
Plant: 114.97.11-1
PACKING

8 HP 45 SW /
PACKING



Bildtafel:
Figure: 114.97.11
Figure:
Figura:

Verpackung
Packing
Tole de verrouillage
Lamiera di bloccaggio

* je nach Stücklistenausführung
depending on spec. number
suivant la nomenclature
secondo la distinta base

02-06-12

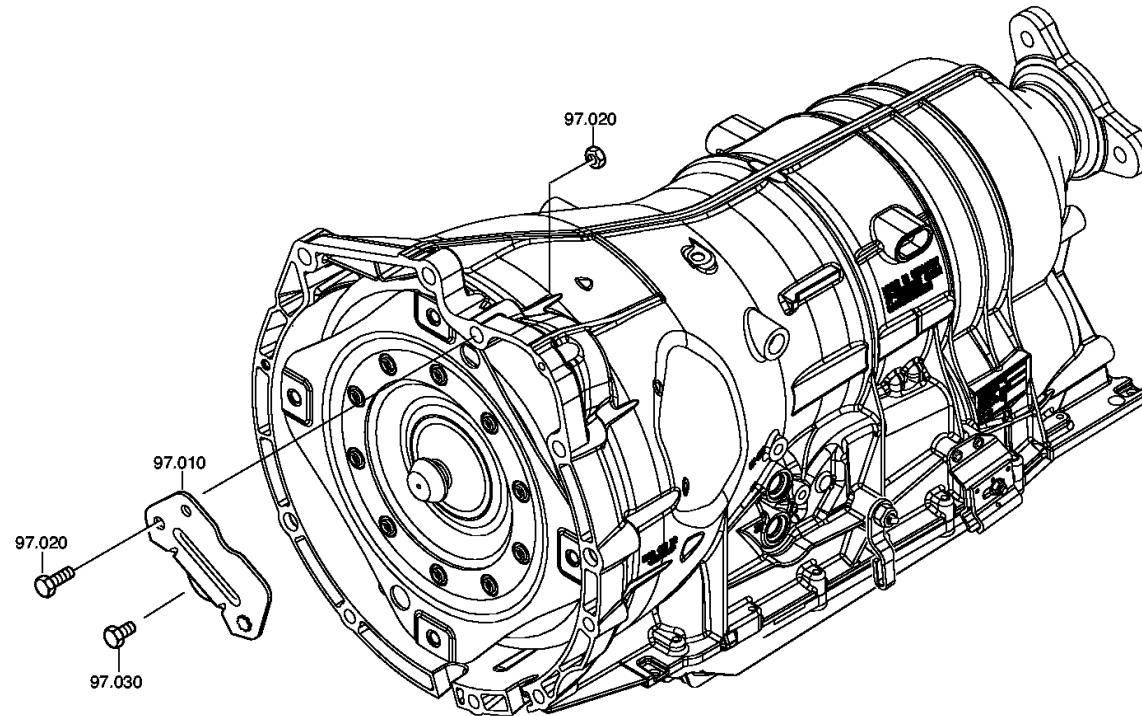

6 HP 26
BMW M57

Parts list

Page 1 from 1

Material number: 1090.010.003

8 HP 45 SW /

Plant: 114.97.11-1

Material-assembly-group-no: 1071.197.903



Pos.	Material number	Customer material	Name	Quantity	ME	Amend. no.	Techn. Info.	Weight	Rep kit	Alternative material
10	1071.397.038		RETAINING CLIP	1			NG4/6	0,452		
20	---		BOLT+NUT	1			M10X55	0,000		
---	0636.015.136		HEXAGON BOLT	1			M10X55	0,038		
---	0637.006.022	0637 006 022	HEXAGON NUT	1			M10	0,010		
30	---		HEXAGON BOLT	1			M10X16	0,000		
---	0636.015.270	1000000358	HEXAGON BOLT	1			M10X16	0,020		

Parts list

Page 1 from 1

Material number: 1090.010.003

8 HP 45 SW /

Material-assembly-group-no: 6058.008.065



Pos.	Material number	Customer material	Name	Quantity	ME	Amend. no.	Techn. Info.	Weight	Rep kit	Alternative material
	6058.008.065		E-MODUL 8-GANG	1		Z00006410310	D2-MUSTER	0,600		