



# 6HP26

6-Gang-Automatgetriebe für Pkw  
6 speed automatic transmission for cars



<b>Getriebetyp / Transmission type</b>		<b>6HP26</b>	
<b>Antriebsart</b> Type of drive		Standard / Standard drive	
<b>Eingangsdrehmoment</b> Input torque		max. 440 Nm	max. 600 Nm
<b>Drehmomentwandler</b> Torque converter		W255RH- 4GWK	W270RH-4GWK
<b>Standard-Übersetzungen / Standard ratios</b>			
Gang / Gear	1	4.17	
	2	2.34	
	3	1.52	
	4	1.14	
	5	0.87	
	6	0.69	
	R	3.40	
<b>Getriebespreizung</b> Transmissions spreading		6.04	
<b>Masse</b> ohne Anbauteile (incl. Öl) <b>Weight</b> without ancillaries (incl. oil)		84 kg	89 kg
<b>Ölmenge</b> Oil capacity		≈ 10 dm <sup>3</sup>	
<b>Getriebeöl</b> Transmission oil		Lebensdauerölfüllung Lifetime oil fill	

# 6HP26

## Einbaumaße / Installation dimensions

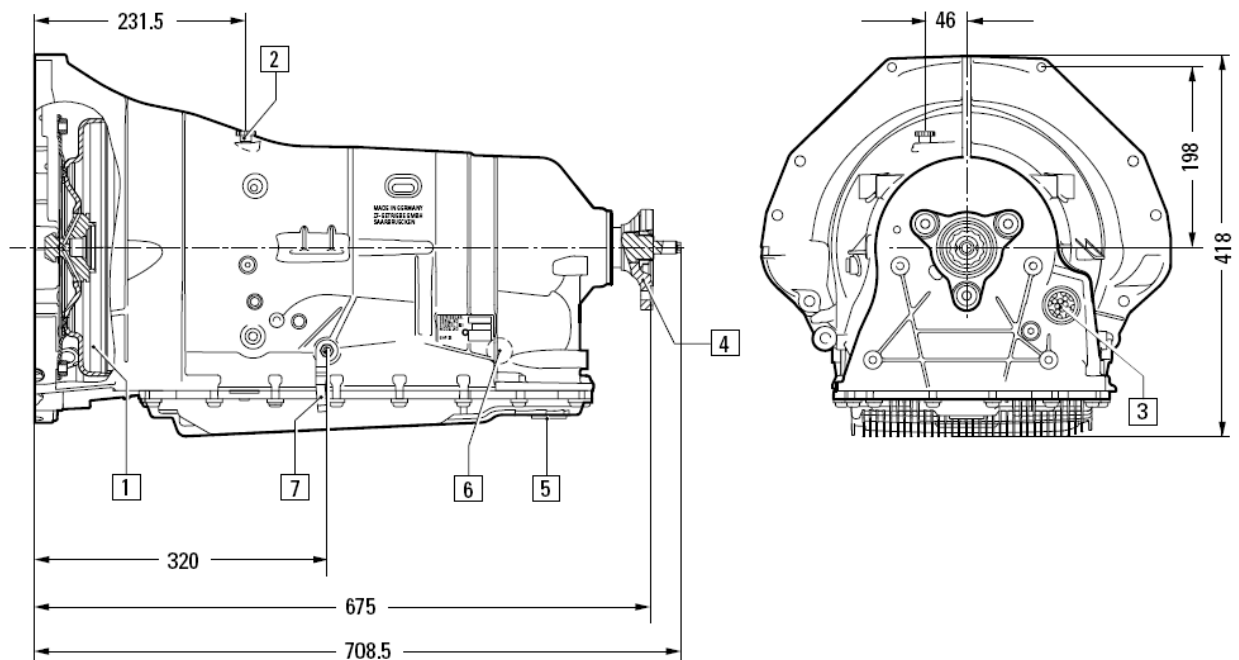

- |   |   |   |   |
|---|---|---|---|
| 1 | Wandler / Torque converter  | 5 | Ölablass / Oil drain  |
| 2 | Entlüfter / Breather  | 6 | Öleinfüllung und Ölüberlaufmessung /<br>Oil fill and oil overflow   |
| 3 | Steckeranschluss zum Fahrzeugsystem /<br>Plug connection to vehicle systems | 7 | Notentriegelung Parksperr (Shift-by-wire) oder<br>Wählhebel (manuell)<br>Emergency disengagement of parking brake<br>(Shift-by-wire) or selector lever (manually) |
| 4 | Abtrieb / Output  |   |   |

## Highlights

- **Standabkopplung / Neutral idle control**
- **Mechatronik (integrierte Getriebesteuerung) / Mechatronic (integrated transmission control)**
- **ASIS - adaptive Schaltstrategie / ASIS - adaptive shifting strategy**
- **Hohe Leistung bei geringem Gewicht (auf Basis des Lepelletier-Radsatzkonzeptes) /  
High power-to-weight ratio (based on Lepelletier gear set concept)**
- **Allradfähig / AWD capable**